

DEVELOPMENT AND FIELD EVALUATION OF A SEEDLING POLYBAG SOIL FILLING MACHINE FOR OIL PALM NURSERY

HASLINA HASSAN¹; AZMI YAHYA^{1,4,5*}; DARIUS EL PEBRIAN^{2*} and AHMAD SUHAIZI MAT SU^{3,4,5}

ABSTRACT

The need to produce high-quality seedlings with adequate quantity has placed a burden on nursery operators, who often require substantial capital and labour with limited daily production capability. The goal of this project was to develop a seedling polybag soil filling machine and evaluate its performance in a simulated oil palm nursery, emphasising small polybag production. The 51 kW diesel engine of a universal, multipurpose 4WD (four-wheel drive) prime mover was utilised to transmit the power to the mixer and auger of the machine system. The recorded average production capacity was 198 bags man hr⁻¹, which was 24.24% higher than the conventional practice of 150 bags man hr⁻¹. The final weight was within the limit (<5%) for both small and large polybags. The production capacity of the machine was moderately improved, despite an increase of approximately 53% in total costs per polybag over the conventional practice. Generally, the machine can be deployed in seedling production of the oil palm nursery stage to fill the polybags with suitable planting media selection.

Keywords: mechanisation, oil palm nursery, polybag machine, seedling polybag, soil filling.

Received: 28 October 2021; **Accepted:** 24 May 2022; **Published online:** 18 July 2022.

INTRODUCTION

Replanting the existing plantation areas is always given great attention by the Malaysian oil palm

industry players as well as smallholders (Ishak *et al.*, 2020) in an effort of sustaining its competitiveness as the second largest palm oil producing country in the world. This is consistent with Ismail and Mamat (2002), who stated that replanting should be conducted in estates having high costs of production but falling profit. Wahid and Simeh (2010) added that the replanting programme should enable changes to the palm supply chain, which catalyses the country's high-income strategy. Smallholders are involved in both the Replanting Subsidiary Scheme for Oil Palm Smallholders (TSSPK) and the Oil Palm Smallholders New Planting scheme (TBSPK) for Independent Smallholders (ISH) (Ishak *et al.*, 2020) that has been established in 2011 as one of the eight Entry Point Projects (EPP) in National Key Economic Area of the 10th Malaysia Plan.

In 2020, there has been a steady supply of germinated oil palm seeds from the oil palm nurseries in the country, despite a decrease in demand by 4.9% from 2019, coupled with a reduction from 41 million to 39 million seeds due to the decrease in oil palm planted areas. Additionally, seedling losses owing to culling procedures account for around 25.0% to

¹ Department of Biological and Agricultural Engineering, Faculty of Engineering, Universiti Putra Malaysia, 43400 UPM Serdang, Selangor, Malaysia.

² Faculty of Plantation and Agrotechnology, Universiti Teknologi MARA, Melaka Branch, Jasin Campus, 77300 Merlimau, Melaka, Malaysia.

³ Department of Agricultural Technology, Faculty of Agriculture, Universiti Putra Malaysia, 43400 UPM Serdang, Selangor, Malaysia.

⁴ Institute of Plantation Studies, Universiti Putra Malaysia, 43400 UPM Serdang, Selangor, Malaysia.

⁵ Smart Farming Technology Research Centre, Faculty of Engineering, Universiti Putra Malaysia, 43400 UPM Serdang, Selangor, Malaysia.

* Corresponding author e-mail: azmiy@upm.edu.my, darius@uitm.edu.my

30.0% and 20.0% to 25.0% of seedling losses in single-stage and double-stage nurseries, respectively, which averaged approximately 15.0% (Ab Rahman *et al.*, 2008). As a result, an additional 15.0% of the annual demand must be added to the seedling preparation. This strategy is only conceivable with better nursery seedling variety selection, pest, and disease management (Rebitanim *et al.*, 2020), and the addition of a new mechanism or machinery system that facilitates seedling planting.

In fulfilling the extensive demand for high-quality germinated seeds for the replanting and new planting areas throughout the country, two nursery techniques were commonly applied at the oil palm nursery, *i.e.*, single-stage and double-stage nursery techniques (Turner and Gillbanks, 2003). In the single stage, the germinated seeds are planted directly into the large polybags (45 x 38 cm) at the main nursery without any pre-nursery activities. In the double-stage, the germinated seeds are first planted in small polybags (23 x 15 cm) and then arranged together in the special pre-nursery beds. These small polybags will be left on the beds for about 10 to 14 weeks before they are transplanted into large polybags (Duckett, 1989). Rankine and Fairhurst (1999) stated that the double-stage nurseries are generally preferred because the seeds can be given intensive care and attention during the critical early growth period.

The current practices in seedling production were tedious and laborious which contributed significantly to the worker's fatigue and stress. In addition, labour shortage in the oil palm plantation sector has now become a contributing factor in slowing down the seeds production for planting in new areas and replanting the present areas. The current labour usage in the oil palm plantations was only about 4 to 5 ha per worker. There have been very few studies attempted to build machinery for oil palm nursery operations, such as those conducted by Johari and Pebrian (2015) and Johari *et al.* (2020) for holing soil in large polybags at the nursery. However, their machinery was not specifically designed for soil filling in polybags.

This study presents the development and field evaluation processes of a newly developed seedling polybag soil filling machine, for use with a 23 x 15 cm size polybag in the oil palm nursery. This machine system is attached to a universal carrier 4WD prime mover with a 51 kW diesel engine size.

MATERIALS AND METHODS

Time and Motion Study on the Current Practice in Nursery

Before designing the proposed machine system, a time and motion study on the current operation of soil filling in polybags was carried out at an oil palm nursery in Tun Razak Agricultural Research Centre, Felda Jengka, Pahang, Malaysia (Figure 1). In this study, filling polybags with soil was divided into several tasks (Table 1). The duration to perform each task in the whole operation was also measured. Three workers were involved in the operation. This data was used as a benchmark to improve the processes and optimise the performance in the design of the proposed machine system.

Time for arranging the working area with wooden planks refers to the total time when the worker starts arranging the borders of the working area with available wooden planks. In the nursery, the working area for this operation has been already bordered by wooden planks. The workers are required to do a minor arrangement of the wooden planks before starting the actual work tasks. Time for breaking the soil clod and delivering the soils with a wheelbarrow refers to the total time when the worker starts breaking soil clods at the soil heap area and delivering the soils on the ground at the filling area. Filling polybags with soil refers to the total time when the worker starts filling a polybag with soil until it is filled. Planting germinated seeds refers to the total time when the worker starts planting a germinated seed in a polybag until it is completely planted.



(a) Breaking soil clods and delivering the soil to the filling area with a wheelbarrow.



(b) Filling polybags with soil.



(c) Planting germinated seeds.

Figure 1. Typical tasks involved in filling polybags with soil in current practice at oil palm nursery.

TABLE 1. TASK DURATION FOR FILLING POLYBAGS WITH SOIL IN THE CURRENT PRACTICE AT THE OIL PALM NURSERY

Tasks	Mean task duration, s man bag ⁻¹	Proportion (%)
Arranging the working area with wooden planks	0.60	3.55
Breaking soil clods and delivering the soils with a wheelbarrow to the filling area	1.88	11.10
Filling polybags with soil	9.92	58.83
Planting germinated seeds	4.46	26.45
Total	16.86	100.00

The proportion of task duration was calculated by dividing a task duration by the total completion time of the operation. Filling polybags with soil was the most time-consuming task which took the largest share of about 58.83% of the total time in pre-nursery operation, followed by planting germinated seeds, breaking soil clods and delivering the soil to the filling area. Meanwhile, arranging the working area using wooden planks consumed about 3.55% of the total time, being the least time-consuming task in the operation (Table 1). The total completion time of the operation with the current practice was 16.86 s. Production capacity of the current practice (bags man hr⁻¹) was computed by dividing 1 hr or 3600 s by the mean total completion time of current practice (s man per bag) and multiplying the computed value by field efficiency (%). An average of 70% field efficiency was assumed to be sustained for 8 hr within the workday. This is taken into consideration as stated by Nybo *et al.* (2001), the consistency of humans’ physical performance may decrease due to the increased working hours and other working environment factors. Thus, with a mean total completion time of 16.86 s man bag⁻¹, and assuming 70% field efficiency, the computed production capacity of current practice would be 150 bags man hr⁻¹.

Machine Design Criteria

The following criteria were considered in establishing the basic design of the seedling polybag soil filling machine system:

- Simple in construction, operation, and maintenance
- Fully integrated as a one-unit machine system with the universal, multipurpose 4WD prime mover
- Ergonomically constructed to reduce worker fatigue in conducting the operation
- Efficient in operation, with good working productivity with less manpower requirement
- Robust in construction, for high machine durability in rough working conditions

Machine Design Configuration

The design concept of the machine system as in Figure 2, consists of the hopper, mixing agitator, screw delivery auger, and operator and support platform. The overall dimension of the machine is 560 cm in length, 202 cm in width, and 259 cm in height. This machine is fully mounted on a universal, multipurpose 4WD prime mover with an engine size of 51 kW at the rated speed of 2600 rpm. This new machine (Figure 3) is used for filling planting media in 23 cm x 15 cm sized polybags or small-sized polybags.

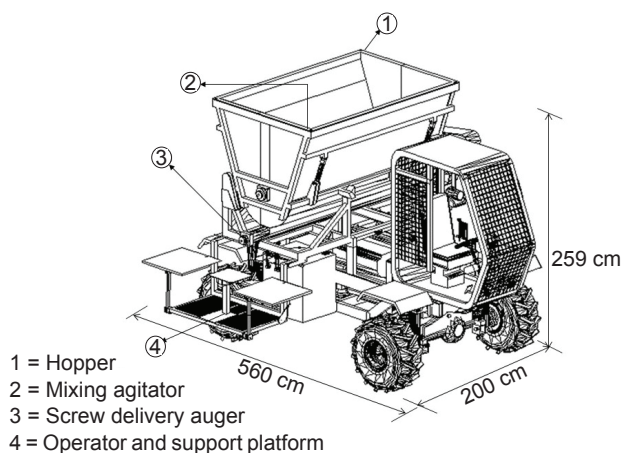

Figure 2. The 3D (three-dimensional) design concept of machine system fully mounted on a 4WD prime mover.



Figure 3. The prototype machine system is mounted on a 4WD prime mover.

Hopper. The hopper was designed to accommodate about 1.5 t of planting media. With a full capacity hopper, it can produce a total of about 1071 small sized polybags (23 x 15 cm), with each having an average weight of 1.4 kg. The hopper was constructed using a 4 mm thick mild steel (MS) sheet and has a trapezoidal shape with overall dimensions of 215 cm length x 145 cm width x 123 cm height. The front and rear walls of the hopper were hinged at the bottom to provide the possibility for the walls to be tilted towards the hopper's longitudinal centre by the action of the two small 4 cm bore x 20 cm stroke hydraulic cylinders on each side of the walls. This action is necessary to be done intermittently during the machine operation to overcome the clogging problems of the planting media in the hopper. This action, at the same time, could also help to push the planting media towards the hopper's longitudinal centre at the position where the screw deliver auger was positioned. The whole hopper was pivoted at its rear to support the frame structure, to allow the hopper to tip rearwards. These actions could be done hydraulically by the two 7 cm bore x 38 cm stroke hydraulic cylinders that were located on the sides of the hopper. Tipping of the hopper is necessary for clearing the planting media in the hopper before and after the polybag filling operation. This hopper was mounted to a common support frame that was made from 75 x 50 x 6 mm MS hollow sections. This same support frame was also used to provide the attachment facilities for other components that make up the complete polybag filling machine. All the earlier mentioned six hydraulic cylinders were powered by a Ronzio-11 tandem gear pump, with 11.3 cm³ rev⁻¹ displacement at 330 bar continuous pressure that was mounted in tandem with the Sauer Danfoss Series 40 main pump of the 4WD multipurpose prime mover.

Mixing agitator. A mixing agitator unit (Figure 4) was designed to break the clods and at the same time provide a homogenous planting media mixture in the hopper. The agitator had four MS blades

with dimensions of 14 x 37 cm and was mounted on a rotating shaft located along with the centre longitudinal position of the hopper. This mixing agitator functions to turn and mix the planting media and prevents the occurrence of planting media blockage in the hopper which may hinder the easy flow of the mixture into the screw delivery auger at the bottom of the hopper. The rotating power for the mixing agitator in the hopper was provided by the Ronzio-20 tandem gear pump, with 20.1 cm³ rev⁻¹ displacement at 230 bar continuous pressure that was also connected in tandem to the Sauer Danfoss Series 40 main pump of the 4WD multipurpose prime mover. The power of the pump was used to run the Samhydraulik ARC 80 hydraulic with a 1:50 gear reduction (HU85A-WN, Watt Drive, Singapore) and finally a sprocket-chain drive system with a ratio of 1:2 and its driven pulley mounted on the mixing agitator shaft. With such speed reduction, the desired rotational speed of 9 rpm could be made possible for the mixing agitator.

Screw delivery auger. The screw delivery auger was designed to deliver the planting media out from the hopper at the required discharge rate into an awaiting polybag that is located at the outlet end of the screw deliver auger chute. The rotating power for this 6 cm diameter size and 7.5 cm pitch screw delivery auger is provided by the Ronzio-6 tandem gear pump with 6.28 cm³ rev⁻¹ displacement at 300 bar continuous pressure that was also connected in tandem to the Sauer Danfoss Series 40 main pump of the 4WD multipurpose prime mover. The rotating power from the hydraulic motor was then made to run a worm-type reduction gear with a 1:5 reduction ratio and a sprocket-chain drive system with a 1:2 reduction ratio to provide a final screw delivery auger rotational speed of 150 rpm. The screw delivery auger was operated by controlling the Ronzio-6 tandem gear pump through a foot pedal level located in the closed vicinity of the machine operator seat.



Figure 4. The mixing agitator is on top of the screw delivery auger in the hopper.

Operator and support platform. The operator and support platform where the major operation and control activities are being conducted by the machine operator. A comfortable seat is provided at the right side of the hopper and located close to the opening end of the screw delivery auger chute. Human-machine factors were considered in designing the seat to ensure comfort, easiness, and safety for the operator in carrying out his tasks. All hydraulic hand lever controls for the hopper cylinder hydraulics and mixing agitator motor was positioned at the operator's hand level position on the right side of the operator seat while the foot pedal level control for the screw delivery auger motor was positioned at the operator's foot level position at the right side of the operator seat. A support platform was provided at either side of the operator seat for the temporary placement of the filled polybag. A specially made wooden tray measuring 61 cm width x 61 cm length x 15 cm height, with eight equal space components was used to accommodate 8 filled polybags at one time. This wooden tray was used to transfer the filled polybags to the final seedling placement location in the nursery. About 10 sets of these wooden trays were used during the machine operation.

Machine Operation

This 4WD prime mover, with the mounted polybag filling machine system is operated by two operators; the prime mover driver, who conducts the filling of the polybags and drives the prime mover, while another operator carries and unloads the filled polybags from the wooden tray at the seedling placement area. Before starting the operation, the heaped planting media is loaded into the hopper of the machine. Prior to that, the planting media needs to be manually cleared from the presence of residual roots, woods, small stones and other debris. Lifting the planting media into the hopper of the machine system was done by a tractor with a front loader. Upon completion of filling the hopper to its full capacity, the operator would drive the 4WD prime mover with the mounted machine system to the place where the polybag filling operation is to be conducted within the available nursery area. This chosen working area shall also be the place where the filled polybags later were to be permanently kept in the nursery. The actual work starts with the running of the mixing agitator on the machine system while keeping the 4WD prime mover engine running ideal under a stationary mode position. The mixing agitator shall be left continuously running for at least 5 min to make sure that the planting media in the hopper was properly mixed and not clogged.

Field Performance Evaluation of the Developed Prototype Machine System

A field performance evaluation test on the developed prototype machine system was conducted for the polybag soil filling operation using a 23 x 15 cm sized polybag (small size) and 45 x 38 cm sized polybag (large size) under a simulated field environment at the laboratory (Figures 5 and 6). The test on the small-sized polybags was for the production of 400 units of the filled polybags while the test on the big-sized polybags was for the production of 100 units of the filled polybags. The same evaluation test on the machine system was repeated for three different days.

Generally, the completed work which involved filling the polybag with soil using this machine system for the seed planting operation in the nursery area involves the following five main tasks; 1. Filling polybags with soil, 2. Loading the filled polybags into a wooden tray/wheelbarrow, 3. Carrying or transporting filled polybags to seedling placement location in the nursery, 4. Unloading and arranging the filled polybags at the seedling placement location, 5. Carrying or transporting back the empty wooden tray/wheelbarrow to the machine. A millisecond digital stopwatch was used to measure the duration of time taken by the operator in completing each of the earlier five tasks for the preparation of 400 units of small and 100 units of largely filled polybags for the day. Polar S810 Heart Rate Monitor and Transmitter (Polar, 2013) were placed in direct contact with the upper body of the two operators for monitoring their heart rate while they were conducting the relevant tasks throughout the daily operation. This instrument had been proven to provide valid measurements of heart rate when compared with electrocardiograms (Karvonen *et al.*, 1984; Leger and Thivherge, 1988; Treiber *et al.*, 1989).

The definition of time durations measured in the time and motion study of the developed prototype machine system is tabulated in Table 2. The proportion of task duration was calculated by dividing a task duration by the total completion time of the operation.

Ten small-sized filled polybags and 10 large-sized filled polybags were randomly picked from the pool of the respective polybags after the third day of the soil filling operations with the machine system. The weight of these selected filled polybags was taken and recorded by using a Sartorius BCE8200-1S electronic weighing scale. Duncan's Multiple Range Test (DMRT) was applied to compare the mean task duration performed by the workers and the mean increase in heart rate of workers at a 0.05 probability level.

TABLE 2. THE DEFINITION OF TIME DURATIONS MEASURED IN THE TIME AND MOTION STUDY OF THE DEVELOPED PROTOTYPE MACHINE SYSTEM

Time duration	Definition
Time for filling a polybag with soil	Total time from when the machine operator starts placing an empty polybag to the outlet delivery auger chute until the time when the polybag was completely filled with soil
Time for loading eight filled small polybags on the wooden tray	Total time from when the operator starts loading the first filled small polybag into the wooden trays and repeating these steps until a total of eight filled small polybags were in the wooden tray
Time for loading four filled large polybags into the wheelbarrow	Total time from when the operator starts loading the first filled large polybag into the wheelbarrow and repeating these steps until a total of four filled large polybags were in the wheelbarrow
Time for carrying or transporting the fully loaded wooden tray	Total time from when the operator starts carrying the fully loaded wooden tray to the seedling placement location
Time for carrying or transporting fully loaded wheelbarrow	Total time from when the operator starts pushing the fully loaded wheelbarrow to the seedling placement location
Time for unloading and arranging the polybags (small size) at the seedling placement location	Total time from when the operator starts pulling the floor bottom of the wooden tray for the small filled polybags to be left on the ground at the seedling placement location
Time for unloading and arranging the polybags (large size) at the seedling placement location	Total time from when the operator starts unloading the first large filled polybag from the wheelbarrow and placing the polybag on the ground at the seedling placement location and repeats the task until a total of four filled polybags were on the ground at the seedling placement location
Time for carrying back the empty wooden tray to the machine system	Total time from when the operator starts carrying back the empty wooden tray from the seedling placement location to the machine system
Time for carrying back the empty wheelbarrow	Total time from when the operator starts pushing back the empty wheelbarrow from the seedling placement location to the machine system



(a) Filling polybag with soil.



(b) Loading the filled polybags in a wooden tray.



(c) Carrying the loaded wooden tray to the seedling placement location.



(d) Unloading and arranging the polybags at seedling placement location.



(e) Carrying the empty wooden tray back to the machine.

Figure 5. The tasks involved soil filling of small polybags with the machine system.



(a) Filling polybag with soil.



(b) Loading the filled polybags in a wheelbarrow.



(c) Transporting the loaded wheelbarrow to the seedbed.



(d) Unloading and arranging the polybags at the seedbed.



(e) Transporting the emptied wheelbarrow to the machine.

Figure 6. The tasks involved filling large polybags with the machine system.

RESULTS AND DISCUSSION

Overall Field Performance of Machine System

Tables 3 and 4 show the mean task duration and mean increase in the heart rate of the worker in completing the respective tasks with this new machine system. The task involved was interpreted either as time-consuming tasks or demanding tasks. Any task within the operation that showed the longest duration proportion would be regarded as the most time-consuming, while any task with the highest mean increase in heart rate would be regarded as the most demanding.

For small polybags as seen in Table 3, filling polybags with soil took about 48.02% of the mean total time and was the most time-consuming task among all other tasks that are involved with the machine system. Carrying a filled polybag in a wooden tray to the seedling placement location and carrying back an empty wooden tray to the machine system spent 5.23% and 5.01% of the mean total time and were the least time-consuming tasks. During filling the polybag with soil, the machine operator spent more time tapping and shaking the polybag to obtain the right firmness and content of the soil in the polybag. On the other hand, carrying the loaded wooden tray to the seedling placement location and carrying back the empty wooden tray to the machine system was the least time-consuming since the location of the seedling placement location with the machine system was quite close. Loading the

filled polybags into the wooden tray and carrying the wooden tray to the seedling placement location where the two most demanding tasks since both showed the highest mean increase in heart rate of the operator.

For large polybags as in Table 4, filling polybags with soil took about 49.12% of the mean total time and was the most time-consuming task among the respective tasks. Transporting the loaded wheelbarrow and transporting the empty wheelbarrow back to the machine location spent about 3.72% and 4.33% of the mean total time. These two tasks were the least time-consuming tasks. As before, the operator spent a long time filling the polybag with soil since he had to frequently tap and shake the polybag to obtain the right firmness and content of the soil in the polybag. Nonetheless, with the large-sized polybag, the task was longer than the smaller sized polybags since a bigger volume and weight of soil mass was involved as compared with the earlier task with smaller sized polybags. Transporting the loaded wheelbarrow to the seedling placement location and transporting emptied wheelbarrow back to the machine system were the least time-consuming since the location between the seedbed and machine system was quite close. However, loading the filled polybags into the wheelbarrow, and unloading and arranging the filled polybags at the seedling placement location were the two most demanding tasks, as reflected by the highest mean increase in heart rate of the operator.

TABLE 3. TASK DURATION AND HEART RATE INCREASE OF WORKERS IN FILLING SMALL POLYBAGS WITH SOIL BY MACHINE SYSTEM

Task ¹	Number of replicates	Mean task duration (s man bag ⁻¹)	Proportion (%)	The mean increase in heart rate (beats min ⁻¹)
Filling polybag with soil	400	8.73 ^a ± 0.13	48.02	9.26 ^d ± 0.29
Loading the filled polybags into wooden tray	400	3.70 ^b ± 0.32	20.35	42.91 ^a ± 1.69
Carrying filled polybag in wooden tray to seedling placement location	400	0.95 ^c ± 0.06	5.23	41.84 ^a ± 1.42
Unloading and arranging the filled polybags at the seedling placement location	400	3.89 ^b ± 0.15	21.40	26.29 ^c ± 1.01
Carrying back empty wooden tray to machine system	400	0.91 ^c ± 0.06	5.010	28.58 ^b ± 1.24

Note: ¹Means in a given column having suffices with the same letters are treated not significantly different at 0.05 probability level by DMRT.

TABLE 4. TASK DURATION AND HEART RATE INCREASE OF WORKERS IN FILLING LARGE POLYBAGS WITH SOIL BY MACHINE SYSTEM

Task ¹	Number of replicates	Mean task duration (s man bag ⁻¹)	Proportion (%)	The mean increase in heart rate (beats min ⁻¹)
Filling polybag with soil	100	26.65 ^a ± 0.67	49.12	8.21 ^c ± 0.46
Loading filled polybags in wheel barrow	100	19.41 ^b ± 1.57	35.77	28.07 ^a ± 1.76
Transporting filled polybag in a wheelbarrow to the seedling placement location	100	2.02 ^d ± 0.19	3.72	24.39 ^b ± 1.61
Unloading and arranging the filled polybag at the seedling placement location	100	3.82 ^c ± 0.29	7.04	29.16 ^a ± 1.77
Transporting back empty wheel barrow to machine system	100	2.35 ^d ± 0.14	4.33	24.79 ^b ± 1.68

Note: ¹Means in a given column having suffices with the same letters are treated as not significantly different at 0.05 probability level by DMRT.

Generally, if further improvements can be made on this new machine system, the focus should be strategically made on the design improvement on the parts of the machine system, which were the most time consuming and demanding in completing the tasks within the whole operation.

Table 5 shows the production capacity comparison between using the new machine system and current practice in small polybag soil filling operations. Comparison with the large polybag was not possible here because there was no available data on the production capacity with large polybags using the current practising manual operation method at the nursery. The production capacity of this new machine system (bags man hr⁻¹) was computed by dividing 1 hr or 3600 s by the mean total completion time of this new machine system (s man per bag). With a mean total completion time of 18.18 s man bag⁻¹ for all tasks in Table 3, thus, the computed production capacity of the new machine system was 198 bags man hr⁻¹ or 24.24% higher than the output of 150 bags man hr⁻¹ of the current practice at the nursery.

TABLE 5. PRODUCTION CAPACITY COMPARISON BETWEEN MACHINE SYSTEM AND CURRENT PRACTICE IN SMALL POLYBAG SOIL FILLING OPERATION

Parameter	Operational methods		Differences (%)
	Current practice	Machine system	
Production capacity (bags man hr ⁻¹)	150 ^a	198 ^b	24.24

Note: ^{a,b} Means in a given row having sufficed with the same letters are treated not significantly different at 0.05 probability level by DMRT.

Generally, the weight of polybags with soil was slightly higher than the recommended weight. The average weight of small polybags with soil was 2.44 kg or exceeded 38.00% of the recommended weight of 1.5 kg per polybag by Turner and Gilbanks (2003). The same situation also occurred when filling large polybags, where the average weight of large polybags with soil was 18.91 kg or exceeded 20.67% of the expected weight of 15.00 kg as suggested by Turner and Gilbanks (2003). The extra soil being filled in both the small and large polybags was due to the judgment error by the operator while conducting the soil filling task with the machine

system. Further design improvement by installing a weight sensor and control systems on the chute of the screw delivery auger would greatly help the machine system to consistently produce the recommended weight of soil-filled polybag.

Costs Analysis

An estimated total market price of RM101 975 for the machine system was derived from the sum of RM61 975 for the prime mover and RM40 000 for the soil bagging machine attachment. The estimated economic life of the prime mover with the machine attachment was computed based on the economic life of 16 000 hr for the 4WD tractors (ASABE, 2015b) divided by the total operating hours of the tractor in a year. The proposed estimated economic life was considered since the prime mover itself acts as a universal carrier for conducting other field operations such as field seedling transplanting, circle spraying, and in-field FFB collection-transportation. The total annual operating hours for the individual machine systems were estimated based on the listed parameters (Pebrian and Yahya, 2012; Roodi *et al.*, 2011) as shown in *Table 6*.

The actual total annual operating hours of the prime mover with the polybag soil filling machine system were expected to be 2251 hr based on the operation frequency of one time a year (Ghani *et al.*, 2001), average oil palm plantation estate size of 1005 ha (EPU, 2010) with a total of 1 336 680 million palm trees and a planting density of 136 palms ha⁻¹, and a machine output of 1584 bags man day⁻¹.

The machine system was assumed to have salvage values of 10% of its initial purchase price (Kepner *et al.*, 1982). Tax, shelter, and insurance are 2% of the total initial costs of the machine systems (ASABE, 2015a). An interest rate on the higher extreme value of 10% was assumed under the

present economic scenario in Malaysia. Repair and maintenance factors *RF1* of 0.003 and *RF2* of 2.0 were assumed for the new machine system based on the value of repair and maintenance factors for the 4WD tractors (ASABE, 2015b). Lubricant costs of the machine systems were estimated to be 15% of their fuel costs based on the study by Kepner *et al.* (1982). The daily standard wage for a tractor operator in an oil palm plantation is RM4.48 hr⁻¹ based on personal communications with two oil palm plantation managers in Selangor and Pahang.

Thus, the estimated total cost of operation of the new machine system was RM25.65 hr⁻¹ as in *Table 7*. With the machine production capacity of 198 bags man hr⁻¹, thus, the total cost of filling polybag operation would be RM0.13 bag⁻¹ or slightly higher than that the costs of the current practice at RM0.06 bag⁻¹. An increment of about 53% in total costs per polybag was due to the high initial cost of the new machine. The depreciation cost was the highest among the cost components of the machine due to the estimated market price of the proposed machine system which was on the high side as the machine is in the prototype stage. Nonetheless, a small upgrade to the current machine system by the installation of a sensing and control circuit to the auger unit is highly recommended. Having such a system could help in speeding up the soil filling task and at the same time regulate the amount of soil going into the polybag, resulting in a significant increase in machine output capacity to justify the machine's high total cost.

CONCLUSION

A polybag soil filling machine system for the oil palm nursery had been successfully developed and evaluated. The machine has a mobility advantage

TABLE 6. REQUIRED NUMBER OF MACHINE SYSTEMS AND THEIR RESPECTIVE ANNUAL TOTAL OPERATING HOURS FOR AN AVERAGE-SIZED OIL PALM PLANTATION¹

Machine system	Frequency of operation in a year	Machine field capacity, ha day ⁻¹ or bags man day ⁻¹	Total required number of machine systems, dimensionless	Total annual operating hours for each machine system (hr)
Prime mover with a seedling polybag soil filling machine	1	1584	3	2 251
Prime mover with seedling transplanting	1	6.002	1	1 340
Prime mover with circle spraying	4	7.893	2	2 038
Prime mover with FFB infield collection transporting	26	14.163	6	2 460

Note: ¹ Based on an average plantation size of 1005 ha and available total working days in the year of 312 days. (Pebrian and Yahya, 2012; Roodi *et al.*, 2011)

TABLE 7. ESTIMATED TOTAL COSTS OF THE DEVELOPED SOIL BAGGING MACHINE

Cost component	Cost (RM hr ⁻¹)	Proportion of total cost (%)	Rank based on the highest cost
Depreciation cost	5.82	22.69	1
Interest on investment cost	2.49	9.71	5
Tax, shelter and insurance cost	0.91	3.55	6
Repair and maintenance cost	4.82	18.79	4
Fuel consumption cost	5.65	22.03	2
Lubricants cost	0.85	3.31	7
Operator cost	5.11	19.92	3
Total costs	25.65	100.00	

since it is fully mounted onto a specially developed 4WD prime mover. Being mobile, this machine system could be transported to conduct the polybag soil filling operation at the seedling placement location in an open area of the oil palm nursery. The machine system performance could be further improved through proper refinement in its design and proper training for the person who is operating the machine system.

REFERENCES

- ASABE (2015a). ASAE Standards EP 496.3 FEB 2006 (R2015). *Agricultural Machinery Management*. American Society of Agricultural and Biological Engineers (ASABE). <https://elibrary.asabe.org/standards.asp>, accessed on 1 May 2019.
- ASABE (2015b). ASAE Standards D 497.7 MAR 2011 (R2015). *Agricultural Machinery Management Data*. American Society of Agricultural and Biological Engineers (ASABE). <https://elibrary.asabe.org/standards.asp>, accessed on 1 May 2019.
- Ab Rahman, A K; Ramli, F; Shariff, S M and Simeh, M A (2008). The Malaysian palm oil supply chain: The role of the oil palm nursery operators. *Oil Palm Industry Economic J.*, 8(1): 24-33.
- Duckett, J E (1989). *A Guide to Oil Palm Nurseries*. The Incorporated Society of Planters. Kuala Lumpur, Malaysia. p. 6-80.
- EPU (2010). *Principle Statistics of Oil Palm Estates 2000-2008*. Economics Planning Unit Malaysia. <http://www.epu.jpm.my.>, accessed on 1 February 2015.
- Ghani, E A; Dolmat, M T and Wahid, M B (2001). *Manual Penanaman dan Penyelenggaraan Sawit untuk Sektor Pekebun Kecil*. MPOB, Bangi. p. 4-20.
- Ishak, S M; Aman, Z and Taib, H M (2020). An evaluation on outcome of oil palm replanting scheme (TSSPK) and new planting scheme (TBSPK). *Int. J. Mod. Trends in Soc. Sci.*, 3(14): 129-148.
- Ismail, A and Mamat, M N (2002). The optimal age of oil palm replanting. *Oil Palm Industry Economic J.*, 2(1): 11-18.
- Johari, N A A and Pebrian, D E (2015). Development of a self-propelled machine for holing soil in large polybags in oil palm nursery. *Proc. of the 10th Asian Control Conference (ASCC 2015)*. Kota Kinabalu, Malaysia. p. 1114-1118.
- Johari, N A A; Pebrian, D E; Vaiappuri, S K N and Hayum, N A (2020). Preliminary field and costs evaluation of a new mechanised system for holing soil in large polybag in oil palm nursery. *J. Oil Palm Res.*, 32(2): 228-236.
- Karvonen, J; Chwalbinska-Moneta, J and Saynajakangas, S (1984). Comparison of heart rates measured by ECG and microcomputer. *Phys. Sportsmed.*, 12(6): 65-69.
- Kepner, R A; Bainer, R and Barger, E L (1982). *Principles of Farm Machinery*. 3rd edition. AVI Publishing Company, Inc. Westport, Connecticut. USA. p. 23-60.
- Leger, L and Thivherge, M (1988). Heart rate monitors: Validity, stability and functionality. *Phys. Sportmed.*, 16(5): 143-151.

- Nybo, L; Jensen, T; Nielsen, B and Gonzalez-Alonso, J (2001). Effects of marked hyperthermia with and without dehydration on VO₂ kinetics during intense exercise. *J. Appl. Psychol.*, 90(3): 1057-1064.
- Pebrian, D E and Yahya, A (2012). New mechanized system for circle spraying of oil palms seedling emergence. *Sci. Agric.*, 69(2): 85-100.
- Polar (2013). *Heart Rate Monitor*. <http://www.polar.com>, accessed on 17 October 2015.
- Rankine, I R and Fairhurst, T H (1999). *Field Handbook Oil Palm Series: Nursery. Volume 1*. Oxford Graphic Printers Pte. Ltd, Singapore. p. 16-90.
- Roodi, S M; Yahya, A and Aziz, S A (2011). Field performance of a single chassis integrated machine system in planting oil palm seedlings. *J. Agr. Machy. Sci.*, 7(2): 185-190.
- Rebitanim, N A; Hanafi, M M; Idris, A S; Abdullah, S N A; Mohidin, H and Rebitanim, N Z (2020). GanoCare® improves oil palm growth and resistance against *Ganoderma* basal stem rot disease in nursery and field trials. *BioMed Res. Internat.*, (2020): 1-16.
- Treiber, F A; Musante, L; Hartdagan, S; Davis, H; Levy, M and Strong, W B (1989). Validation of a heart rate monitor with children in laboratory and field settings. *Med. Sci. Sport. Exerc.*, 21(3): 338-342.
- Turner, P D and Gillbanks, R A (2003). *Oil Palm Cultivation and Management*. 2nd edition. The Incorporated Society of Planters. Kuala Lumpur, Malaysia. p. 173-254.
- Wahid, M B and Simeh, M A (2010). Accelerated oil palm replanting: The way forward for a sustainable and competitive industry. *Oil Palm Industry Economic J.*, 10(2): 29-38.